

LongLife LED MR16 is a designed evolution. Manufactured with high quality aluminum heat sink & leading industrial LED modules. We devote ourselves to reduce the cost, while improving our lumens and quality. Our products are eco-friendly, without toxic materials, energy saving, and 100% made in Taiwan. Easy installation, instantly switch on, without UV and RF.

For all the reasons above, our products are "Long Life."

LED 7W MR16 規格表

產品編號	LMR16-7T1A-C0	LMR16-7T1A-W0
消耗功率	7W ± 10%	7W ± 10%
輸入電壓	12~18Vac / 12~24Vdc	12~18Vac / 12~24Vdc
電流	<700mA	<700mA
照射角度	30°/45°/60°	30°/45°/60°
色溫	5300K~7000K	2600K~3300K
流明值	480 ± 10%Lm	400 ± 10%Lm
演色性	70	70
操作溫度	-20°C~50°C	-20°C~50°C

特點

- ◇ 低光衰
- ◇ 低熱度
- ◇ 一年保固
- ◇ 台灣製作

地點

- ✓ 商店
- ✓ 辦公室
- ✓ 居家環境
- ✓ 室內空間

➤ 產品圖



淨重: 24g ±10%

➤ 尺寸示意圖

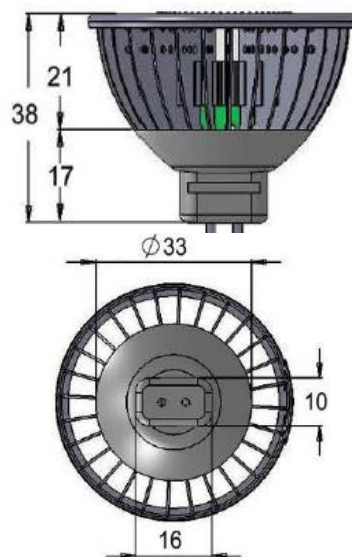

➤ 光照圖<30°產品為例>

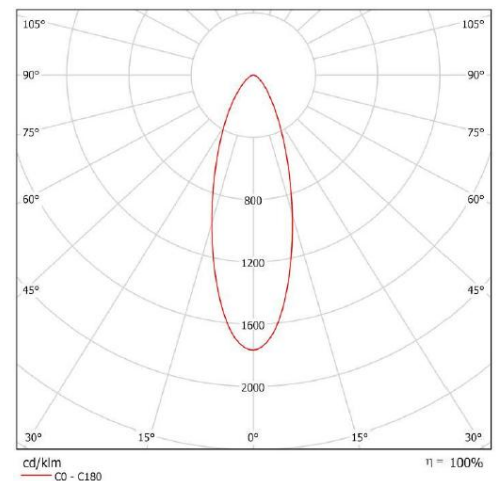

山光科技股份有限公司

桃園市龜山工業區興邦路 33 號 2 樓

電話:+ 886-3-3620863 信箱: sales@sankou.com.tw

更多相關資訊，請參考我們的網站: www.sankou.com.tw

